

OVERVIEW

Emission color: White

Lens appearance: White

Chip: InGaN

Applicable to all SMT assembly methods.

Compatible with infrared and vapor phase reflow soldering processes.

Compatible with automatic placement equipment.

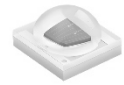

FEATURES:

5050 is a high power package that provides high luminance

from a super robust package to enable cost effective and reliable fixture,5050 uses an industry standard 5050 surface mount package with a fairly small Light Emitting Surface (LES).

Queendom 5050 Multiple color temperatures & high color rendering: 2700K–7600K, supporting CRI > 80/90 options And offers hot-color targeting to ensure that the LEDs are within color target at application

conditions of 85°C. Futhermore, with the latest NightScape Technology,

Durable packaging: anti-sulfurization, anti-UV, and anti-humidity design

APPLICATIONS:

Automobile: dashboard, brake lights, turn signals.

Biomedical optics, instrument and equipment testing

Status indicator: consumer electronics and industrial electronics.

Security, infrared monitoring, night vision

Industrial lighting: factory lights, warehouse lighting, high-power ceiling lights

Automotive lighting: high beam lights, engineering vehicles/special vehicles headlights

Plant lighting/medical light sources: can be matched with customized spectrum versions

ABSOLUTE MAXIMUM RATINGS

Table 1. Absolute maximum ratings for LEDs.

PARAMETER	AXIMUM RATINGS
Parameter PD (mW)	≤14W(3W/CHIP)
DC Forward Current [1, 2]	700mA HP5050W**WF
	1000mA HP5050W**WG
	1400mA HP5050W**WI
Peak Pulsed Forward Current [1, 3]	1200mA HP5050W**WF
	1500mA HP5050W**WG
	1800mA HP5050W**WI
LED Junction Temperature [1] (DC & Pulse)	125°C
Reverse Voltage (Vreverse)	5
ESD Sensitivity (ANSI/ESDA/JEDEC JS-001-2012)	Class 2
LED Storage Temperature	-40°C to 80°C
Operating Temperature Range	Minus 40°C To plus 80°C
Soldering Temperature	JEDEC 020c 260°C
Allowable Reflow Cycles	3~5 Seconds
ESD Sensitivity	2000V HBM

Notes for Table 1: Proper current derating must be observed to maintain the junction temperature below the maximum allowable junction temperature. Single-color light. At 0.01ms pulse on time test with a pulse period of 0.1ms.

PRODUCT MODEL CODE CORRESPONDING SKU TABLE

PRODUCT	RANK	NOMINAL	TEST	PART NUMBER
		CCT/K	(mA)	
HP5050WY2WF	HP0201	2700K	700	8541401000HP0201
HP5050WV2WF	HP0202	3000K	700	8541401000HP0202
HP5050WU2WF	HP0203	3500K	700	8541401000HP0203
HP5050WT2WF	HP0204	4000K	700	8541401000HP0204
HP5050WR2WF	HP0205	5000K	700	8541401000HP0205
HP5050WQ2WF	HP0206	5700K	700	8541401000HP0206
HP5050WP2WF	HP0207	6500K	700	8541401000HP0207
HP5050WD2WF	HP0208	7600K	700	8541401000HP0208
HP5050WY2WG	HP0209	2700K	1000	8541401000HP0209
HP5050WV2WG	HP0210	3000K	1000	8541401000HP0210
HP5050WU2WG	HP0211	3500K	1000	8541401000HP0211
HP5050WT2WG	HP0212	4000K	1000	8541401000HP0212
HP5050WR2WG	HP0213	5000K	1000	8541401000HP0213
HP5050WQ2WG	HP0214	5700K	1000	8541401000HP0214
HP5050WP2WG	HP0215	6500K	1000	8541401000HP0215
HP5050WD2WG	HP0216	7600K	1000	8541401000HP0216
HP5050WY8WI	HP0217	2700K	1400	8541401000HP0217
HP5050WV8WI	HP0218	3000K	1400	8541401000HP0218
HP5050WU8WI	HP0219	3500K	1400	8541401000HP0219
HP5050WT8WI	HP0220	4000K	1400	8541401000HP0220
HP5050WR8WI	HP0221	5000K	1400	8541401000HP0221
HP5050WQ8WI	HP0222	5700K	1400	8541401000HP0222
HP5050WP8WI	HP0223	6500K	1400	8541401000HP0223
HP5050WD8WI	HP0224	7600K	1400	8541401000HP0224
HP5050WY2WI	HP0225	2700K	1400	8541401000HP0225
HP5050WV2WI	HP0226	3000K	1400	8541401000HP0226
HP5050WU2WI	HP0227	3500K	1400	8541401000HP0227
HP5050WT2WI	HP0228	4000K	1400	8541401000HP0228
HP5050WR2WI	HP0229	5000K	1400	8541401000HP0229
HP5050WQ2WI	HP0230	5700K	1400	8541401000HP0230
HP5050WP2WI	HP0231	6500K	1400	8541401000HP0231
HP5050WD2WI	HP0232	7600K	1400	8541401000HP0232

PRODUCT ELECTRICAL INDEX

Table 2. Product performance of Queendom Commercial LEDs at specified test conditions, Continued., T_j=25°C.

PRODUCT	RANK	NOMINAL	CRI	FLUX (lm)		TYPICAL	TEST	PART NUMBER
		CCT/K	[2] Ra	MIN	MAX	2θ 1/2	(mA)	
HP5050WY2WF	HP0201	2700K	80	190	240	120	700	8541401000HP0201
HP5050WV2WF	HP0202	3000K	80	190	240	120	700	8541401000HP0202
HP5050WU2WF	HP0203	3500K	80	190	240	120	700	8541401000HP0203
HP5050WT2WF	HP0204	4000K	80	190	240	120	700	8541401000HP0204
HP5050WR2WF	HP0205	5000K	80	190	240	120	700	8541401000HP0205
HP5050WQ2WF	HP0206	5700K	80	190	240	120	700	8541401000HP0206
HP5050WP2WF	HP0207	6500K	80	190	240	120	700	8541401000HP0207
HP5050WD2WF	HP0208	7600K	80	190	240	120	700	8541401000HP0208
HP5050WY2WG	HP0209	2700K	80	210	430	120	1000	8541401000HP0209
HP5050WV2WG	HP0210	3000K	80	210	430	120	1000	8541401000HP0210
HP5050WU2WG	HP0211	3500K	80	210	430	120	1000	8541401000HP0211
HP5050WT2WG	HP0212	4000K	80	210	430	120	1000	8541401000HP0212
HP5050WR2WG	HP0213	5000K	80	210	430	120	1000	8541401000HP0213
HP5050WQ2WG	HP0214	5700K	80	210	430	120	1000	8541401000HP0214
HP5050WP2WG	HP0215	6500K	80	210	430	120	1000	8541401000HP0215
HP5050WD2WG	HP0216	7600K	80	210	430	120	1000	8541401000HP0216
HP5050WY8WI	HP0217	2700K	80	360	640	120	1400	8541401000HP0217
HP5050WV8WI	HP0218	3000K	80	360	640	120	1400	8541401000HP0218
HP5050WU8WI	HP0219	3500K	80	360	640	120	1400	8541401000HP0219
HP5050WT8WI	HP0220	4000K	80	360	640	120	1400	8541401000HP0220
HP5050WR8WI	HP0221	5000K	80	360	640	120	1400	8541401000HP0221
HP5050WQ8WI	HP0222	5700K	80	360	640	120	1400	8541401000HP0222
HP5050WP8WI	HP0223	6500K	80	360	640	120	1400	8541401000HP0223
HP5050WD8WI	HP0224	7600K	80	360	640	120	1400	8541401000HP0224
HP5050WY2WI	HP0225	2700K	80	360	640	120	1400	8541401000HP0225
HP5050WV2WI	HP0226	3000K	80	360	640	120	1400	8541401000HP0226
HP5050WU2WI	HP0227	3500K	80	360	640	120	1400	8541401000HP0227
HP5050WT2WI	HP0228	4000K	80	360	640	120	1400	8541401000HP0228
HP5050WR2WI	HP0229	5000K	80	360	640	120	1400	8541401000HP0229
HP5050WQ2WI	HP0230	5700K	80	360	640	120	1400	8541401000HP0230
HP5050WP2WI	HP0231	6500K	80	360	640	120	1400	8541401000HP0231
HP5050WD2WI	HP0232	7600K	80	360	640	120	1400	8541401000HP0232

Notes:

The dominant wavelength (λd/cct) is derived from the CIE chromaticity diagram and represents the single wavelength which defines the color of the device.

maintains a ±7.5% tolerance on luminous flux measurements, ±0.15V tolerance on forward voltage measurements, and ±2 tolerance on CRI measurements

Products tested under pulsed condition (10ms pulse width) at nominal drive current.

Typical pulsed test performance values are provided as reference only and are not a guarantee of performance.

ELECTRICAL AND THERMAL CHARACTERISTICS

Table 4 Product performance of Queendom leds at rated current, $T_j=25^{\circ}\text{C}$.

PRODUCT	COLOR	TYPICAL SPECTRAL HALF-WIDTH [1] (K)	TYPICAL TEMPERATURE COEFFICIENT OF DOMINANT WAVELENGTH (CCT/ $^{\circ}\text{C}$)	TYPICAL VIEWING ANGLE [2]	PART NUMBER
HP5050W**	2700K	50	-1.5 ~ -2.0	120 $^{\circ}$	8541401000HP02
	3000K	100	-1.5 ~ -2.0	120 $^{\circ}$	
	3500K	100	-1.5 ~ -2.0	120 $^{\circ}$	
	4000K	120	-1.5 ~ -2.0	120 $^{\circ}$	
	5000K	120	-1.5 ~ -2.0	120 $^{\circ}$	
	5700K	150	-1.5 ~ -2.0	120 $^{\circ}$	
	6500K	249	-1.2 ~ -1.8	120 $^{\circ}$	
	7600K	300	-1.2 ~ -1.8	120 $^{\circ}$	

Notes for Table

Notes for Table 2:Spectral half-width is the spectral bandwidth at 50% of the peak intensity.

Viewing angle is the off axis angle from the LED centerline where the luminous intensity is 1/2 of the peak value.

ELECTRICAL AND THERMAL CHARACTERISTICS

Table5. Product performance of Queendom leds at 700MA rated current, $T_j=25^{\circ}\text{C}$.

Product	COLOR	FORWARD VOLTAGE [1] (Vf)			TYPICAL TEMPERATURE COEFFICIENT OF FORWARD VOLTAGE [2] (mV/ $^{\circ}\text{C}$)	TYPICAL THERMAL RESISTANCE—JUNCTION TO SOLDER PAD ($^{\circ}\text{C}/\text{W}$)
		MINIMUM	TYPICAL	MAXIMUM		
HP5050W*2*	2700K	2.80	3.00	3.20	-2.0 ~ -2.5	6 ~ 8
	3000K	2.80	3.00	3.20	-2.5 ~ -3.0	4 ~ 6
	3500K	2.80	3.00	3.20	-3.0 ~ -3.5	3 ~ 5
	4000K	2.80	3.00	3.20	-2.0 ~ -2.5	6 ~ 8
	5000K	2.80	3.00	3.20	-2.5 ~ -3.0	4 ~ 6
	5700K	2.80	3.00	3.20	-3.0 ~ -3.5	3 ~ 5
	6500K	2.80	3.00	3.20	-2.0 ~ -2.5	6 ~ 8
	7600K	2.80	3.00	3.20	-2.5 ~ -3.0	4 ~ 6
HP5050W*8*	2700K	7.0	9.0	12.00	-2.0 ~ -2.5	6 ~ 8
	3000K	7.0	9.0	12.00	-2.5 ~ -3.0	4 ~ 6
	3500K	7.0	9.0	12.00	-3.0 ~ -3.5	3 ~ 5
	4000K	7.0	9.0	12.00	-2.0 ~ -2.5	6 ~ 8
	5000K	7.0	9.0	12.00	-2.5 ~ -3.0	4 ~ 6
	5700K	7.0	9.0	12.00	-3.0 ~ -3.5	3 ~ 5
	6500K	7.0	9.0	12.00	-2.0 ~ -2.5	6 ~ 8
	7600K	7.0	9.0	12.00	-2.5 ~ -3.0	4 ~ 6

Notes for Table :

Spectral half-width is the spectral bandwidth at 50% of the peak intensity.

Viewing angle is the off axis angle from the LED centerline where the luminous intensity is 1/2 of the pe

CHARACTERISTIC CURVES

SPECTRAL POWER DISTRIBUTION CHARACTERISTIC

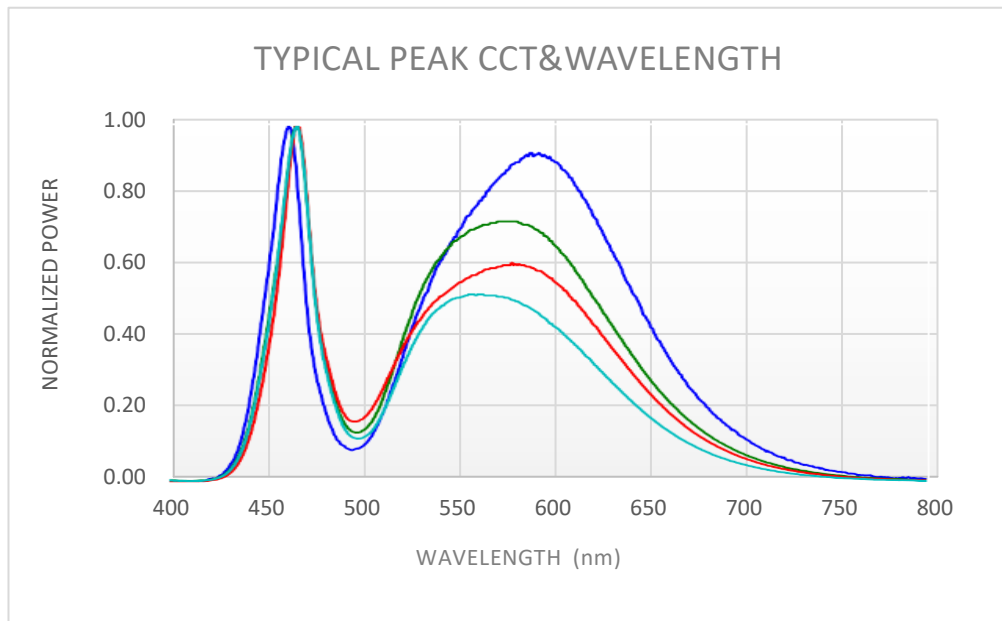

Figure 1. Typical normalized light output vs. junction temperature for at specified test current. $T_j=25^{\circ}\text{C}$

LIGHT OUTPUT CHARACTERISTICS

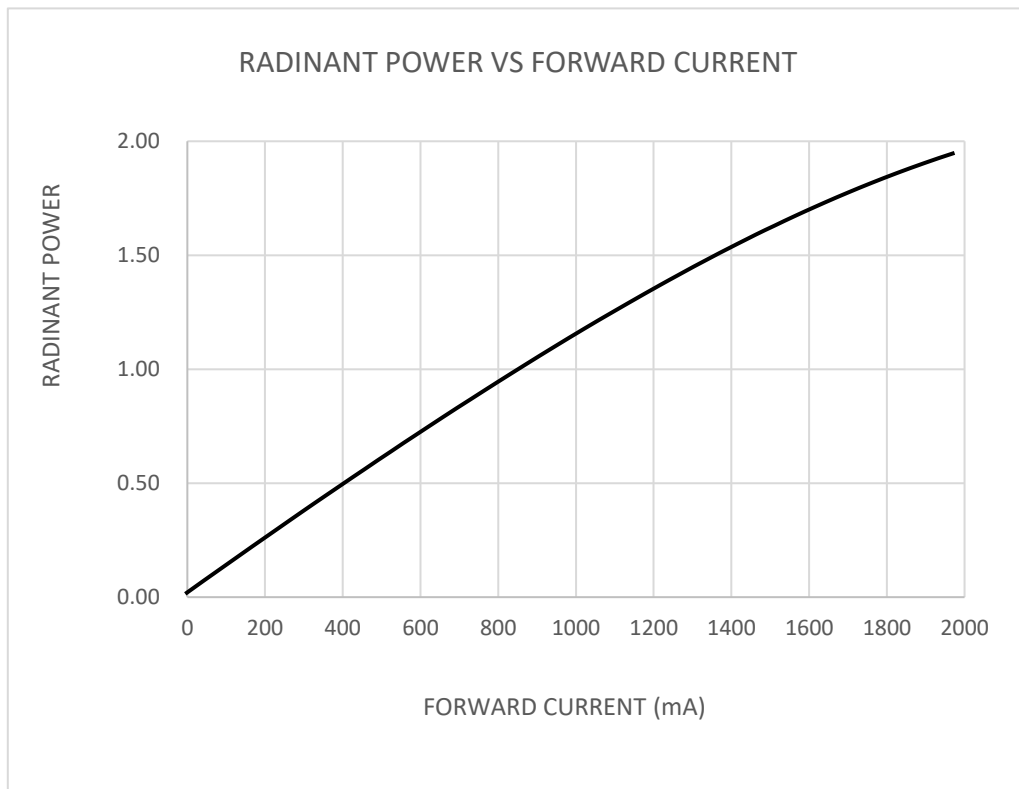

Figure 2 Typical normalized radiant power vs. junction temperature for at $T_j=25^{\circ}\text{C}$.

LIGHT OUTPUT CHARACTERISTICS

HP5050W*2W*

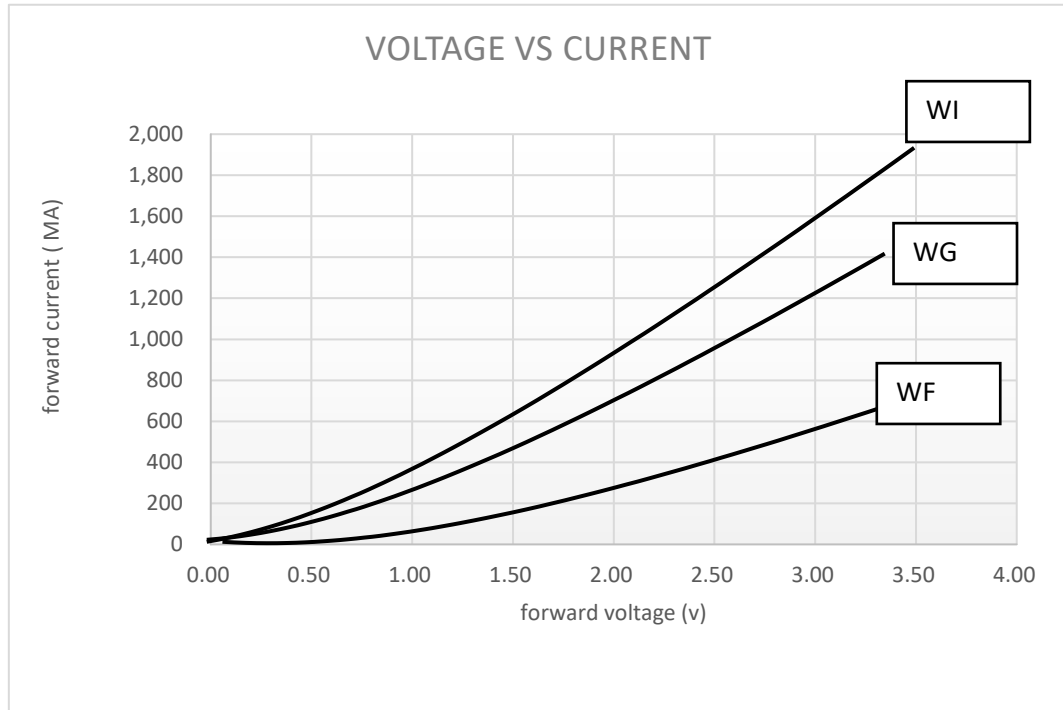

Figure 3. Typical forward current vs. forward voltage for at Tj=25°C.

LIGHT OUTPUT CHARACTERISTICS

HP5050W*8W*

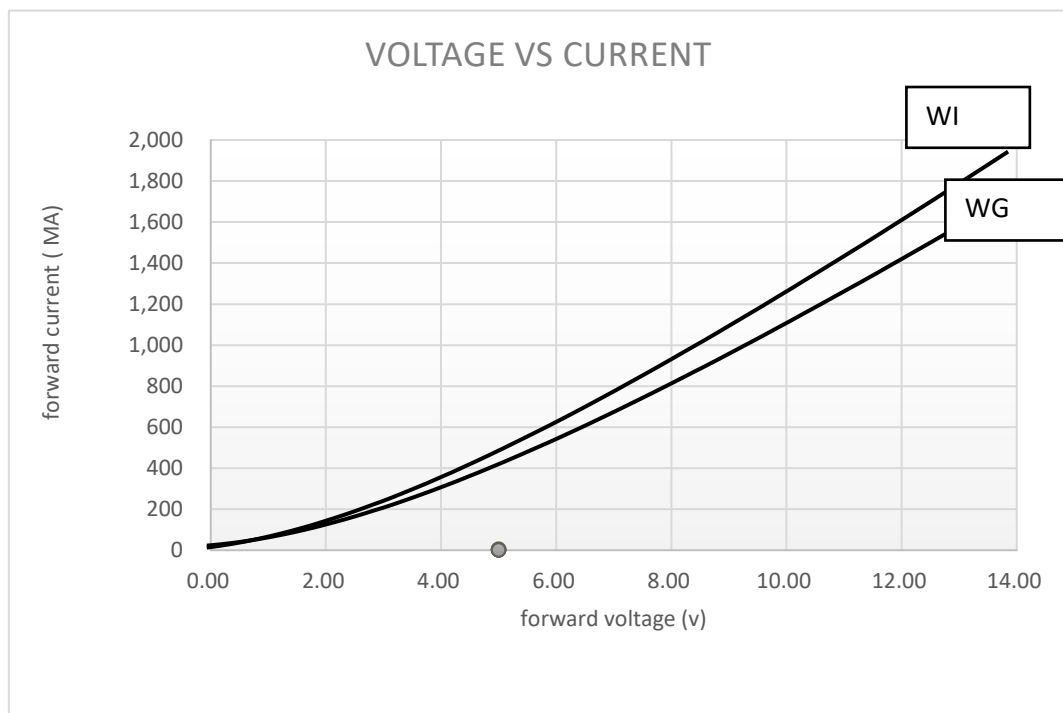

Figure 3. Typical forward current vs. forward voltage for at Tj=25°C.

RADIATION PATTERN CHARACTERISTICS

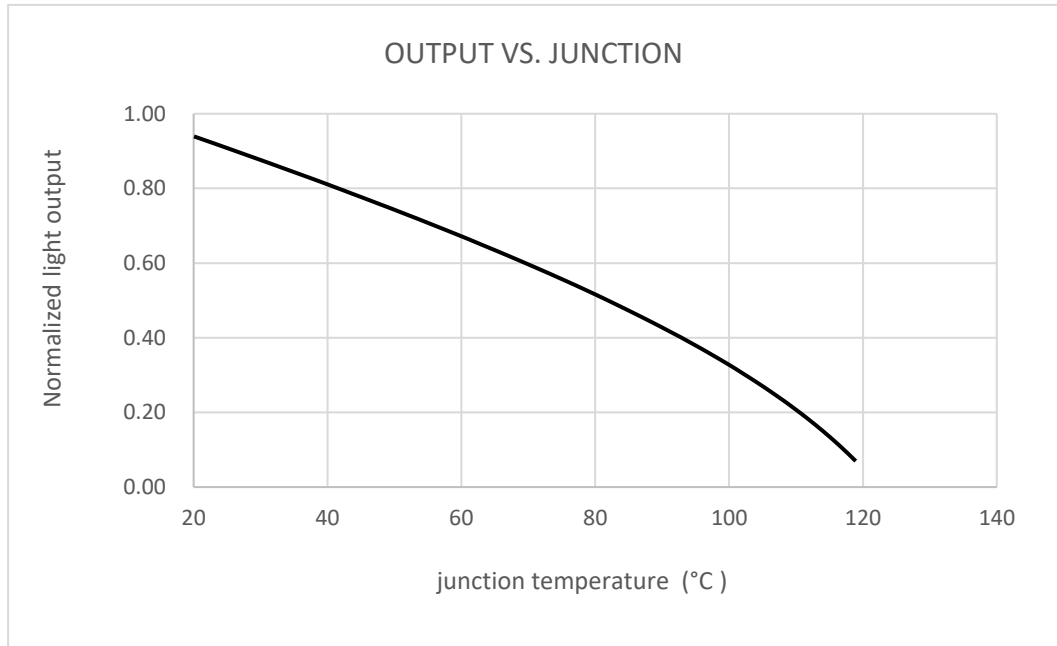
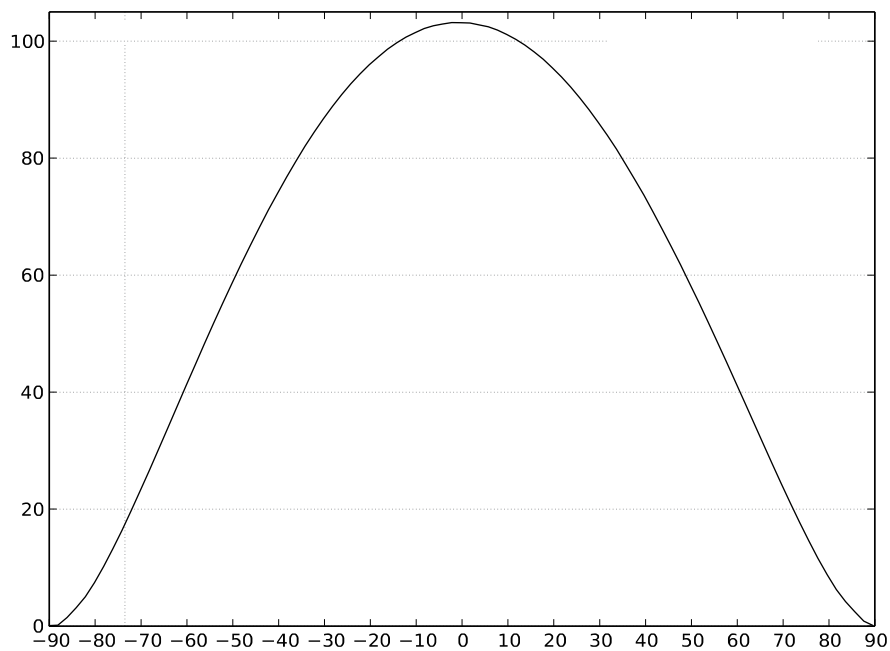

Figure 4. Typical normalized light output vs. junction temperature for at test current.

TYPICAL RADIATION PATTERN



Notes for Figure :

1. Typical viewing angle is 90°.
2. The viewing angle is defined as the off axis angle from the centerline where luminous intensity (Iv) is 1/2 of the peak value.

TYPICAL RADIATION PATTERN

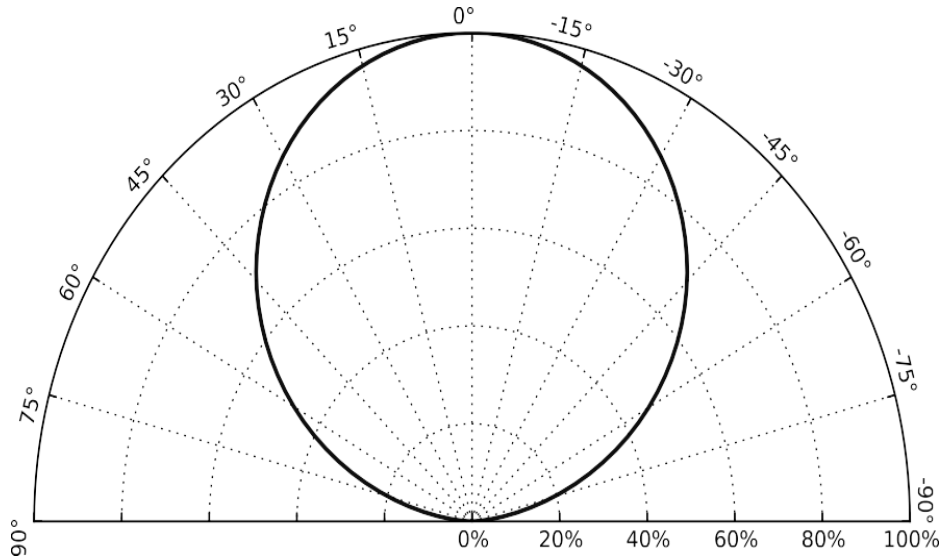
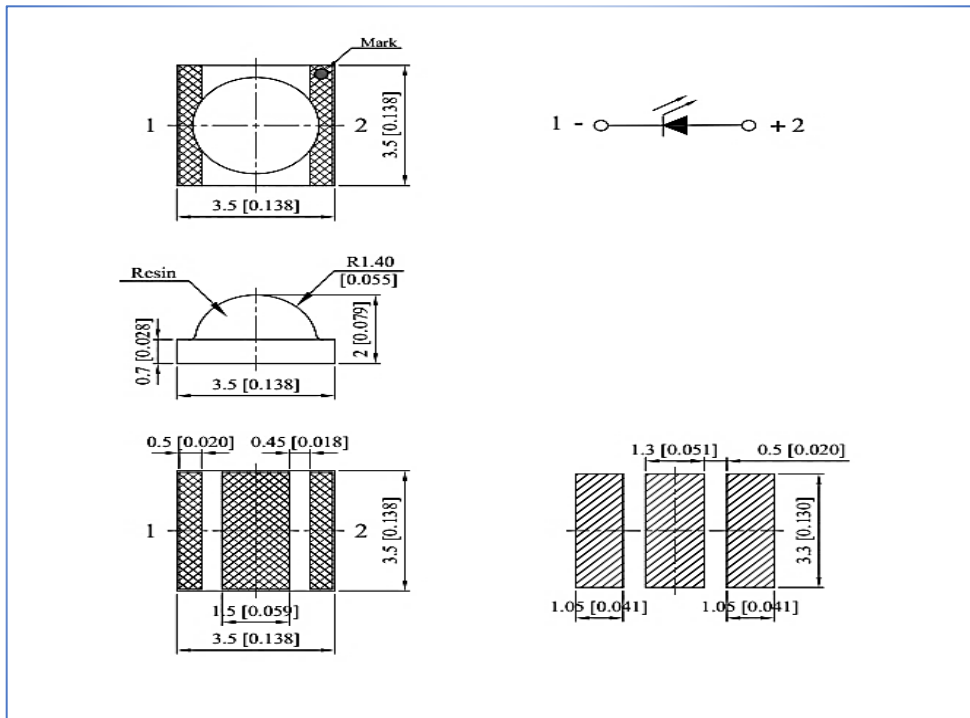
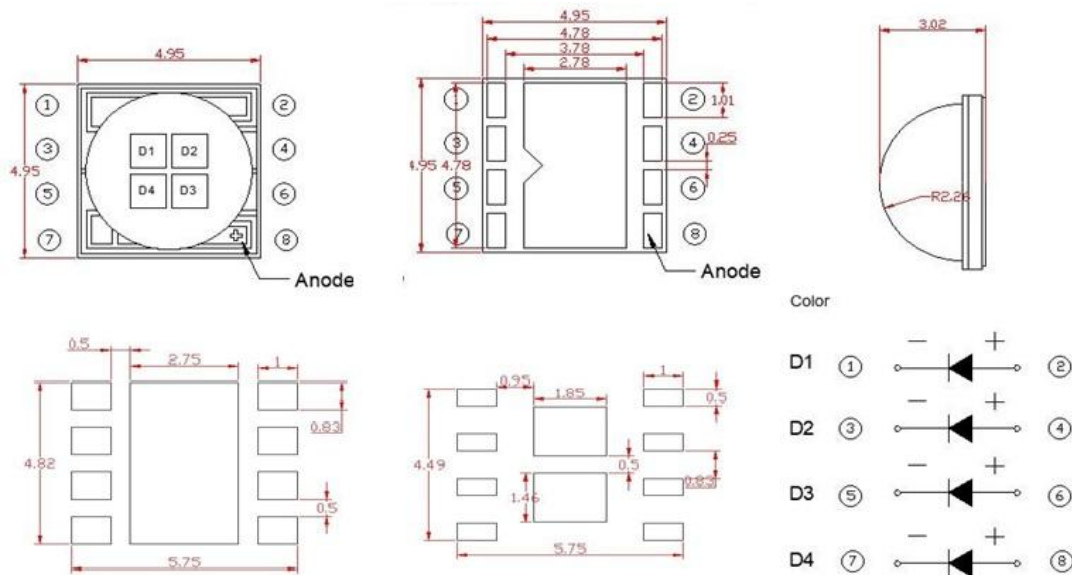

Figure 5. TYPICAL POLAR RADIATION PATTERN AT 700MA, TSP=25°C

DIMENSIONAL DRAWING: HP5050W*2W*



DIMENSIONAL DRAWING: HP5050W*8W*



Notes for Figure :

1. Drawings are not to scale.
2. Drawing dimensions are in millimeters.
3. Unless otherwise specified, tolerances are $\pm 0.10\text{mm}$.

RECOMMENDED SOLDER PAD

For superior solder joint connectivity results we recommend soldering under standard nitrogen atmosphere. Package not suitable for ultra sonic cleaning

Chromaticity Region & Coordinates

Figure 1a. Typical normalized power vs. wavelength for QUEENDOM LEDs, Tj=25°C.

Region	CIE x	CIE y	Region	CIE x	CIE y	Region	CIE x	CIE y	Region	CIE x	CIE y
Y rank (2200 K)						W rank (2700 K)					
Y1	0.4854	0.4022	Y9	0.4974	0.421	W1	0.4417	0.394	W9	0.4515	0.4128
	0.4914	0.4116		0.5033	0.4304		0.4472	0.3953		0.4573	0.4141
	0.4964	0.4116		0.5087	0.4304		0.4522	0.4047		0.4623	0.4235
	0.4903	0.4022		0.5025	0.421		0.4466	0.4034		0.4563	0.4222
Y2	0.4903	0.4022	YA	0.5025	0.421	W2	0.4472	0.3953	WA	0.4573	0.4141
	0.4964	0.4116		0.5087	0.4304		0.4527	0.3966		0.4631	0.4153
	0.5014	0.4116		0.514	0.4303		0.4579	0.4059		0.4683	0.4247
	0.4952	0.4023		0.5077	0.421		0.4522	0.4047		0.4623	0.4235
Y3	0.4952	0.4023	YB	0.5077	0.421	W3	0.4527	0.3966	WB	0.4631	0.4153
	0.5014	0.4116		0.514	0.4303		0.4582	0.3978		0.4689	0.4166
	0.5065	0.4116		0.5194	0.4303		0.4635	0.4072		0.4742	0.426
	0.5	0.4023		0.5129	0.421		0.4579	0.4059		0.4683	0.4247
Y4	0.5	0.4023	YC	0.5129	0.421	W4	0.4582	0.3978	WC	0.4689	0.4166
	0.5065	0.4116		0.5194	0.4303		0.4637	0.3991		0.4747	0.4179
	0.5115	0.4116		0.5247	0.4303		0.4692	0.4085		0.4802	0.4272
	0.5049	0.4023		0.5181	0.421		0.4635	0.4072		0.4742	0.426
Y5	0.4914	0.4116	YD	0.5033	0.4304	W5	0.4466	0.4034	WD	0.4563	0.4222
	0.4974	0.421		0.5093	0.4398		0.4522	0.4047		0.4623	0.4235
	0.5025	0.421		0.5148	0.4398		0.4573	0.4141		0.4673	0.4329
	0.4964	0.4116		0.5087	0.4304		0.4515	0.4128		0.4612	0.4316
Y6	0.4964	0.4116	YE	0.5087	0.4304	W6	0.4522	0.4047	WE	0.4623	0.4235
	0.5025	0.421		0.5148	0.4398		0.4579	0.4059		0.4683	0.4247
	0.5077	0.421		0.5203	0.4397		0.4631	0.4153		0.4735	0.4341
	0.5014	0.4116		0.514	0.4303		0.4573	0.4141		0.4673	0.4329
Y7	0.5014	0.4116	YF	0.514	0.4303	W7	0.4579	0.4059	WF	0.4683	0.4247
	0.5077	0.421		0.5203	0.4397		0.4635	0.4072		0.4742	0.426
	0.5129	0.421		0.5258	0.4397		0.4689	0.4166		0.4796	0.4354
	0.5065	0.4116		0.5194	0.4303		0.4631	0.4153		0.4735	0.4341
Y8	0.5065	0.4116	YG	0.5194	0.4303	W8	0.4635	0.4072	WG	0.4742	0.426
	0.5129	0.421		0.5258	0.4397		0.4692	0.4085		0.4802	0.4272
	0.5181	0.421		0.5313	0.4396		0.4747	0.4179		0.4857	0.4366
	0.5115	0.4116		0.5247	0.4303		0.4689	0.4166		0.4796	0.4354

Figure 1b. Typical normalized power vs. wavelength for QUEENDOM LEDs, Tj=25 °C.

Region	CIE x	CIE y	Region	CIE x	CIE y	Region	CIE x	CIE y	Region	CIE x	CIE y
U rank (3500 K)						T rank (4000 K)					
U1	0.3889	0.369	U9	0.3941	0.3848	T1	0.367	0.3578	T9	0.3702	0.3722
	0.3915	0.3768		0.3968	0.393		0.3726	0.3612		0.3763	0.376
	0.3981	0.38		0.404	0.3966		0.3744	0.3685		0.3782	0.3837
	0.3953	0.372		0.401	0.3882		0.3686	0.3649		0.3719	0.3797
U2	0.3953	0.372	UA	0.401	0.3882	T2	0.3726	0.3612	TA	0.3763	0.376
	0.3981	0.38		0.404	0.3966		0.3783	0.3646		0.3825	0.3798
	0.4048	0.3832		0.4113	0.4001		0.3804	0.3721		0.3847	0.3877
	0.4017	0.3751		0.408	0.3916		0.3744	0.3685		0.3782	0.3837
U3	0.4017	0.3751	UB	0.408	0.3916	T3	0.3783	0.3646	TB	0.3825	0.3798
	0.4048	0.3832		0.4113	0.4001		0.384	0.3681		0.3887	0.3836
	0.4116	0.3865		0.4186	0.4037		0.3863	0.3758		0.3912	0.3917
	0.4082	0.3782		0.415	0.395		0.3804	0.3721		0.3847	0.3877
U4	0.4082	0.3782	UC	0.415	0.395	T4	0.384	0.3681	TC	0.3887	0.3837
	0.4116	0.3865		0.4186	0.4037		0.3898	0.3716		0.395	0.3875
	0.4183	0.3898		0.4259	0.4073		0.3924	0.3794		0.3978	0.3958
	0.4147	0.3814		0.4221	0.3984		0.3863	0.3758		0.3912	0.3917
U5	0.3915	0.3768	UD	0.3968	0.393	T5	0.3686	0.3649	TD	0.3719	0.3797
	0.3941	0.3848		0.3996	0.4015		0.3744	0.3685		0.3782	0.3837
	0.401	0.3882		0.4071	0.4052		0.3763	0.376		0.3802	0.3916
	0.3981	0.38		0.404	0.3966		0.3702	0.3722		0.3736	0.3874
U6	0.3981	0.38	UE	0.404	0.3966	T6	0.3744	0.3685	TE	0.3782	0.3837
	0.401	0.3882		0.4071	0.4052		0.3804	0.3721		0.3847	0.3877
	0.408	0.3916		0.4146	0.4089		0.3825	0.3798		0.3869	0.3958
	0.4048	0.3832		0.4113	0.4001		0.3763	0.376		0.3802	0.3916
U7	0.4048	0.3832	UF	0.4113	0.4001	T7	0.3804	0.3721	TF	0.3847	0.3877
	0.408	0.3916		0.4146	0.4089		0.3863	0.3758		0.3912	0.3917
	0.415	0.395		0.4222	0.4127		0.3887	0.3836		0.3937	0.4001
	0.4116	0.3865		0.4186	0.4037		0.3825	0.3798		0.3869	0.3958
U8	0.4116	0.3865	UG	0.4186	0.4037	T8	0.3863	0.3758	TG	0.3912	0.3917
	0.415	0.395		0.4222	0.4127		0.3924	0.3794		0.3978	0.3958
	0.4221	0.3984		0.4299	0.4165		0.395	0.3875		0.4006	0.4044
	0.4183	0.3898		0.4259	0.4073		0.3887	0.3836		0.3937	0.4001

Figure 1c. Typical normalized power vs. wavelength for QUEENDOM LEDs, Tj=25 °C.

Region	CIE x	CIE y	Region	CIE x	CIE y	Region	CIE x	CIE y	Region	CIE x	CIE y
R rank (5000 K)						Q rank (5700 K)					
R1	0.3366	0.3369	R9	0.3374	0.3554	Q1	0.3218	0.3298	Q9	0.3211	0.3407
	0.3369	0.3431		0.3371	0.3493		0.3222	0.3243		0.3215	0.3353
	0.3407	0.346		0.3411	0.3522		0.3258	0.3275		0.3254	0.3388
	0.3403	0.3398		0.3415	0.3587		0.3256	0.3331		0.3252	0.3444
R2	0.3403	0.3398	RA	0.3415	0.3587	Q2	0.3256	0.3331	QA	0.3252	0.3444
	0.3407	0.346		0.3411	0.3522		0.3258	0.3275		0.3254	0.3388
	0.3446	0.3491		0.3451	0.3554		0.3294	0.3306		0.3293	0.3423
	0.344	0.3427		0.3457	0.3621		0.3294	0.3364		0.3293	0.3481
R3	0.3446	0.3491	RB	0.3451	0.3554	Q3	0.3294	0.3364	QB	0.3293	0.3481
	0.344	0.3427		0.3457	0.3621		0.3294	0.3306		0.3293	0.3423
	0.3477	0.3458		0.35	0.3655		0.333	0.3338		0.3332	0.3458
	0.3485	0.3522		0.3492	0.3587		0.3331	0.3398		0.3333	0.3518
R4	0.3485	0.3522	RC	0.3492	0.3587	Q4	0.3331	0.3398	QC	0.3333	0.3518
	0.3477	0.3458		0.35	0.3655		0.333	0.3338		0.3332	0.3458
	0.3514	0.3487		0.3542	0.369		0.3366	0.3369		0.3371	0.3493
	0.3524	0.3554		0.3533	0.362		0.3369	0.3431		0.3374	0.3554
R5	0.3371	0.3493	RD	0.3376	0.3616	Q1	0.3215	0.3353	QD	0.3207	0.3462
	0.3369	0.3431		0.3374	0.3554		0.3218	0.3298		0.3211	0.3407
	0.3407	0.346		0.3415	0.3587		0.3256	0.3331		0.3252	0.3444
	0.3411	0.3522		0.342	0.3652		0.3254	0.3388		0.325	0.3501
R6	0.3407	0.346	RE	0.3415	0.3587	Q2	0.3254	0.3388	QE	0.325	0.3501
	0.3411	0.3522		0.342	0.3652		0.3256	0.3331		0.3252	0.3444
	0.3451	0.3554		0.3463	0.3687		0.3294	0.3364		0.3293	0.3481
	0.3446	0.3491		0.3457	0.3621		0.3293	0.3423		0.3292	0.3539
R7	0.3446	0.3491	RF	0.3457	0.3621	Q3	0.3293	0.3423	QF	0.3292	0.3539
	0.3451	0.3554		0.3463	0.3687		0.3294	0.3364		0.3293	0.3481
	0.3492	0.3587		0.3507	0.3724		0.3331	0.3398		0.3333	0.3518
	0.3485	0.3522		0.35	0.3655		0.3332	0.3458		0.3334	0.3578
R8	0.3485	0.3522	RG	0.35	0.3655	Q4	0.3332	0.3458	QG	0.3334	0.3578
	0.3492	0.3587		0.3507	0.3724		0.3331	0.3398		0.3333	0.3518
	0.3533	0.362		0.3551	0.376		0.3369	0.3431		0.3374	0.3554
	0.3524	0.3554		0.3542	0.369		0.3371	0.3493		0.3376	0.3616

Figure 1d. Typical normalized power vs. wavelength for QUEENDOM LEDs, Tj=25 ° C.

Region	CIE x	CIE y	Region	CIE x	CIE y
P rank (6500 K)					
P1	0.3068	0.3113	P9	0.3048	0.3207
	0.3106	0.315		0.3089	0.3249
	0.3098	0.3199		0.308	0.3298
	0.3058	0.316		0.3038	0.3256
P2	0.3106	0.315	PA	0.3089	0.3249
	0.3144	0.3186		0.313	0.329
	0.3137	0.3238		0.3123	0.3341
	0.3098	0.3199		0.308	0.3298
P3	0.3144	0.3186	PB	0.313	0.329
	0.3183	0.3224		0.3172	0.3332
	0.3177	0.3278		0.3166	0.3384
	0.3137	0.3238		0.3123	0.3341
P4	0.3183	0.3224	PC	0.3172	0.3332
	0.3221	0.3261		0.3214	0.3373
	0.3218	0.3317		0.321	0.3427
	0.3177	0.3278		0.3166	0.3384
P5	0.3058	0.316	PD	0.3038	0.3256
	0.3098	0.3199		0.308	0.3298
	0.3089	0.3249		0.3072	0.3348
	0.3048	0.3207		0.3028	0.3304
P6	0.3098	0.3199	PE	0.308	0.3298
	0.3137	0.3238		0.3123	0.3341
	0.313	0.329		0.3115	0.3391
	0.3089	0.3249		0.3072	0.3348
P7	0.3137	0.3238	PF	0.3123	0.3341
	0.3177	0.3278		0.3166	0.3384
	0.3172	0.3332		0.316	0.3436
	0.313	0.329		0.3115	0.3391
P8	0.3177	0.3278	PG	0.3166	0.3384
	0.3218	0.3317		0.321	0.3427
	0.3214	0.3373		0.3206	0.3481
	0.3172	0.3332		0.316	0.3436

Product Bin and Labeling Definitions

Decoding Product Bin Labeling

In the manufacturing of semiconductor products, there are variations in performance around the average values given in the technical datasheet. For this reason, Queendom leds bins LED components for luminous flux, intensity, radiometric power, color point, peak wavelength, dominant wavelength and forward voltage.

RANK NOMINAL CCT & COLOR COORDINATES

Chromaticity Region & Coordinates

Table 1a. Electrical and thermal characteristics for Queendom at specified test current, Tj=25°C

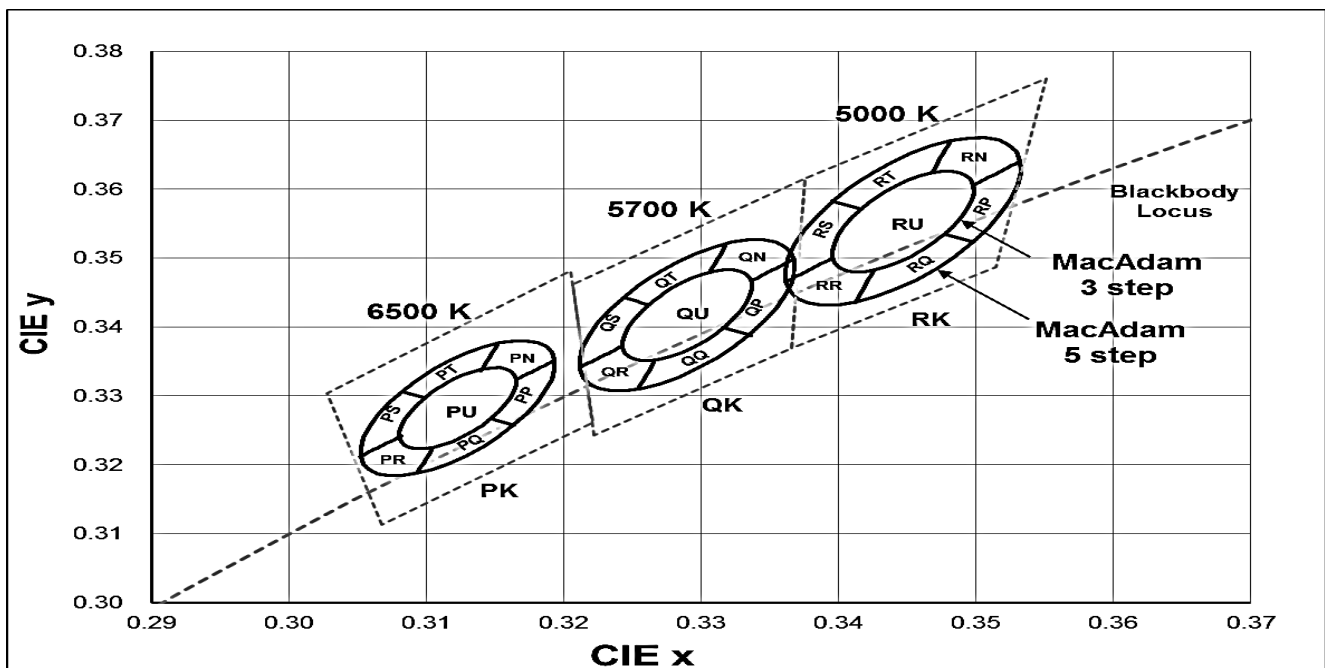
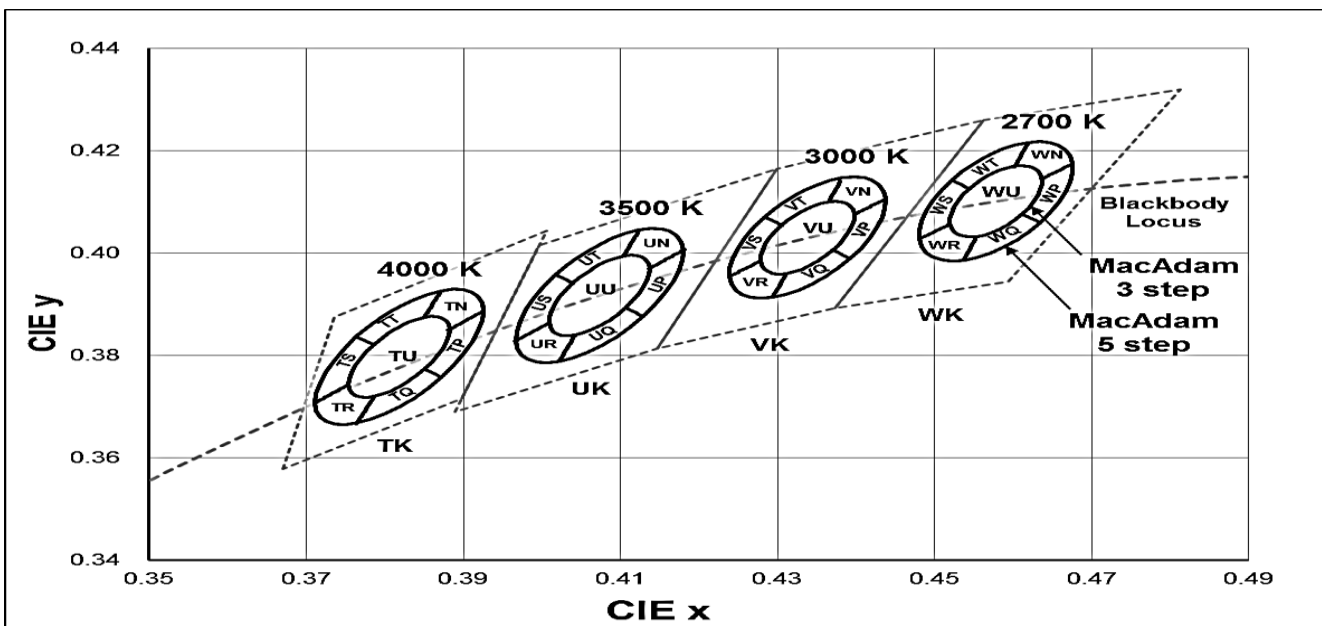

Dominant Wavelength Bins

RANK Table 1. Dominant wavelength bins & Product performance of Queendom Commercial LEDs at specified test conditions.

	Region	CIE x	CIE y	Major-axis	Minor-axis	Rotation
3 step	2700	0.4578	0.4101	0.0081	0.0042	53.7
	3000	0.4338	0.403	0.0083	0.0041	53.22
	3500	0.4073	0.3917	0.0093	0.0041	54
	4000	0.3818	0.3797	0.0094	0.004	53.72
	5000	0.3447	0.3553	0.0082	0.0035	59.62
	5700	0.3287	0.3417	0.0075	0.0032	59.1
	6500	0.3123	0.3282	0.0067	0.0029	58.57
5 step	2700	0.4578	0.4101	0.0135	0.007	53.7
	3000	0.4338	0.403	0.0138	0.0068	53.22
	3500	0.4073	0.3917	0.0155	0.0068	54
	4000	0.3818	0.3797	0.0157	0.0067	53.72
	5000	0.3447	0.3553	0.0137	0.0058	59.62
	5700	0.3287	0.3417	0.0125	0.0053	59.1
	6500	0.3123	0.3282	0.0112	0.0048	58.57

Notes:

1. The tolerance of luminous intensity (Iv) is $\pm 15\%$.
2. The tolerance of dominant wavelength is $\pm 1\text{nm}$.
3. This specification is preliminary.
4. This specification is a standard specification of our factory, can make in accordance with customer's special requirement.

TABLE Forward Voltage BINS

Table 3. Electrical and thermal characteristics for Queendom at specified test current, Tj=25°C

NUMBER	FORWARD VOLTAGE [1] (Vf)			RANK WAVELENGTH [2]		TYPICAL VOLTAGE [3]
	MINIMUM	TYPICAL	MAXIMUM	MINIMUM	MAXIMUM	
V1	1	1.2	1.4	0.1	0.2	0.2
V2	1.4	1.6	1.8	0.1	0.2	0.2
V3	1.8	2	2.2	0.1	0.2	0.2
V4	2.2	2.4	2.6	0.1	0.2	0.2
V5	2.6	2.8	3	0.1	0.2	0.2
V6	3	3.2	3.4	0.1	0.2	0.2
V7	3.4	3.6	3.8	0.1	0.2	0.2
V8	3.8	4	4.2	0.1	0.2	0.2
V9	4.2	4.4	4.6	0.1	0.2	0.2
VA	4.6	4.8	5	0.1	0.2	0.2
VB	5	5.2	5.4	0.1	0.2	0.2
VC	5.4	5.6	5.8	0.1	0.2	0.2
VD	5.8	6				
VE	6	7	8	1	2	2
VF	8	9	10	1	2	2
VG	10	11	12	1	2	2
VH	12	13	14	1	2	2
VI	14	15	16	1	2	2
VJ	16	17	18	1	2	2
VK	18	19	20	1	2	2
VL	20	21	22	1	2	2
VM	22	23	24	1	2	2
VN	24	25	26	1	2	2
VO	26	27	28	1	2	2

TABLE TYPICAL POWER BINS

Table 4. Electrical and thermal characteristics for Queendom at specified test current, Tj=25°C

RANK NO.	TYPICAL POWER RANK (W) [1]		RANK POWER [2] (W)		TYPICAL POWER HALF WIDTH [3] (W)
	min	max	MINIMUM	MAXIMUM	
WE	1	3	1	3	3
WF	3	6	1	3	3
WG	6	9	1	3	3
WH	9	12	1	3	3
WI	12	15	1	3	3
WJ	15	18	1	3	3
WK	18	21	1	3	3
WL	21	24	1	3	3
WM	24	27	1	3	3
WN	27	30	2	3	3
WO	30	34	2	4	4
WP	34	38	2	4	4
WQ	38	42	2	4	4

REEL DIMENSIONS:

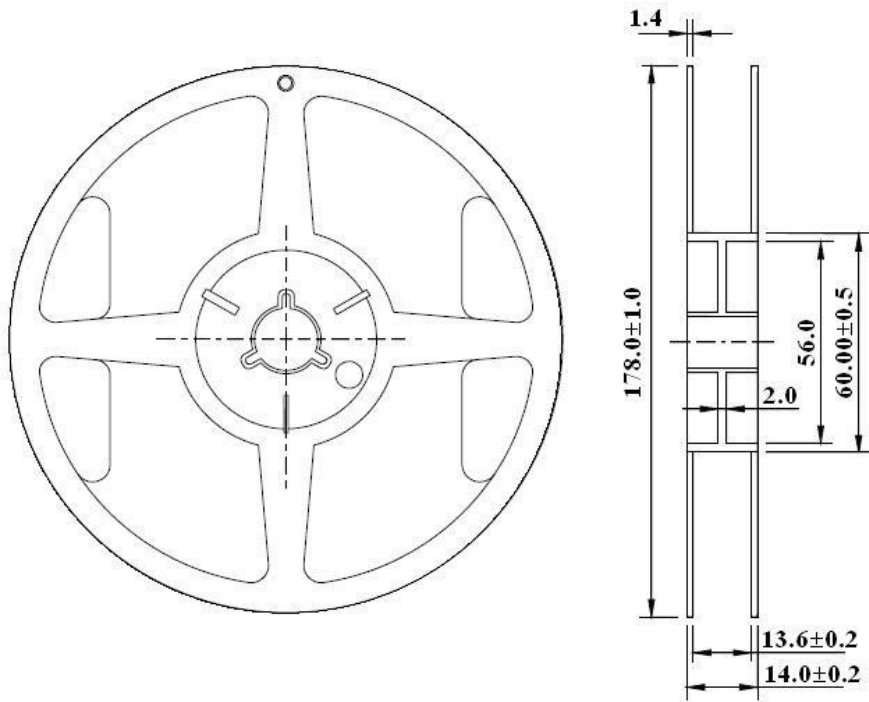

Unit: mm
Tolerance: ± 0.25 mm

CARRIER TAPE DIMENSIONS:

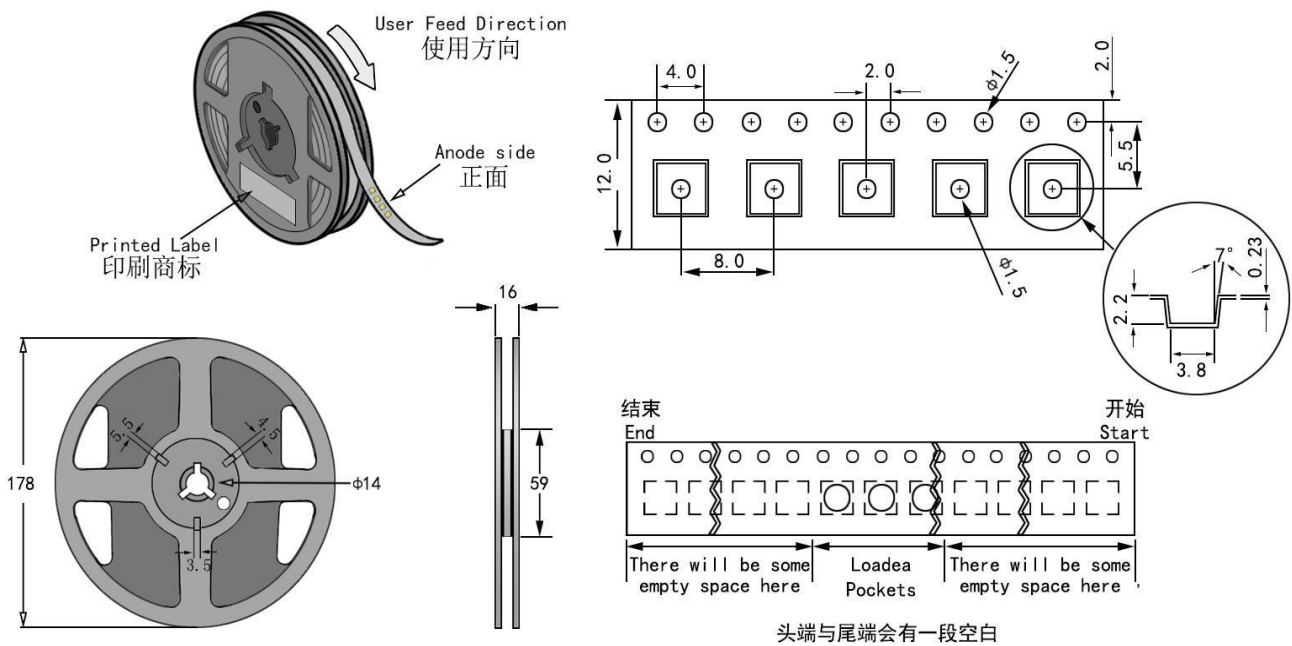

Packaging cartons

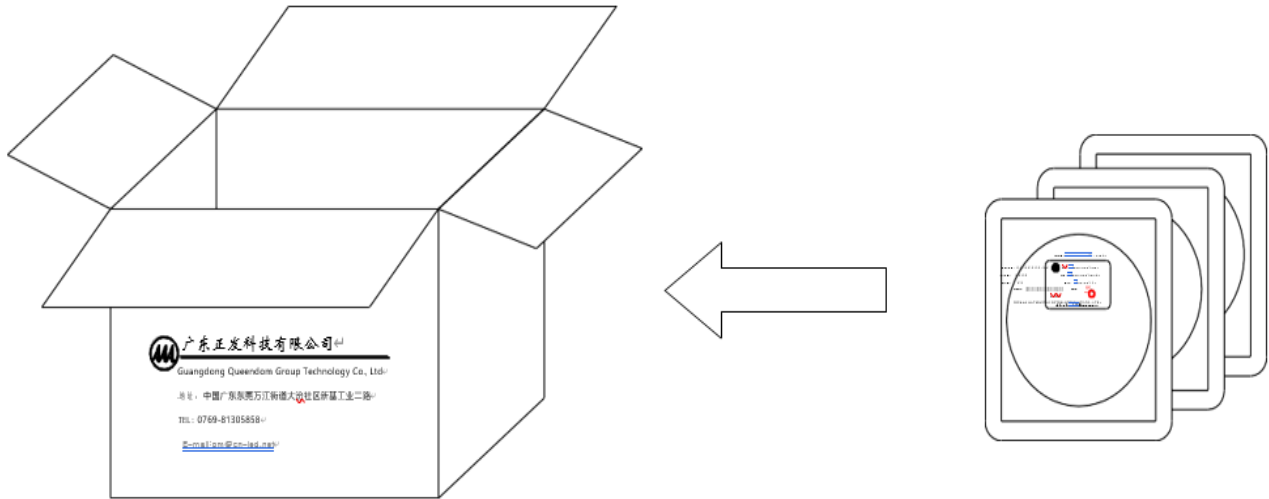

Information

- With Stopper



Without Stopper

CPN:Customer's Product Number
P/N:Product Number
QTY:Packing Quantity
LOT NO:Lot Number
VF:Forward Voltage Rank
IV:Luminous Intensity Rank
WLD:Dom. Wavelength Rank
BIN:BIN Code
DATE: Date Of Dispatch

Packing Quantity

1. 1000 PCS/1 Bag,
2. 10 Inner Cartons/1 Outside Carton

CAUTIONS

Reflow Soldering Guidelines

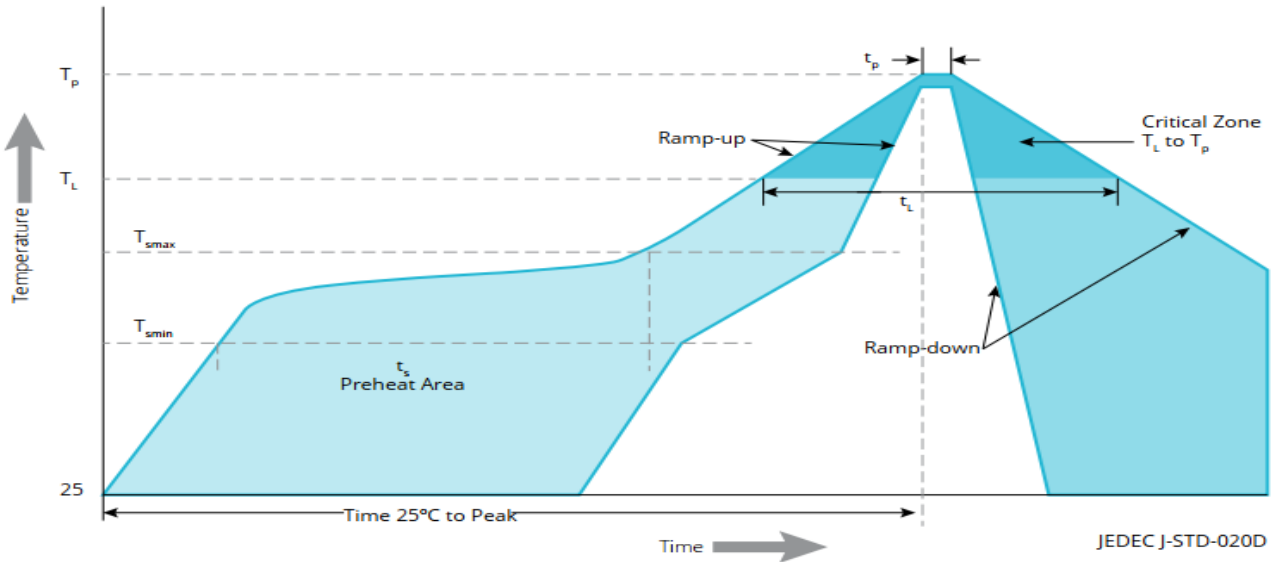

Visualization of the acceptable reflow temperature profile as specified

Reflow profile characteristics for Queendom smd.

Profile Feature	lead-Free assembly
Reheat Minimum Temperature (Tsmmin)	150°C
Preheat Maximum Temperature (Tsmmax)	200°C
Preheat Time (tsmin to tsmax)	60 to 120 seconds
Ramp-Up Rate (TL to Tp)	3°C / second maximum
Liquidus Temperature (TL)	217°C
Time Maintained Above Temperature TL (tL)	60 to 150 seconds
Peak / Classification Temperature (Tp)	260°C
Time Within 5°C of Actual Temperature (tp)	20 to 40 seconds
Ramp-Down Rate (Tp to TL)	6°C / second maximum
Time 25°C to P	8 minutes maximum

JEDEC Moisture Sensitivity

Moisture sensitivity levels for LEDs Line

level	Floor life		soak requirements standard	
	time	conditions	time	conditions
1	Unlimited	≤30°C / 85% RH	168 Hours +5 / -0	85°C / 85% RH

Drive Method

An LED is a current-operated device. In order to ensure intensity uniformity on multiple LEDs connected in parallel in an application, it is recommended that a current limiting resistor be incorporated in the drive circuit, in series with each LED as shown in Circuit A below.

Circuit model A

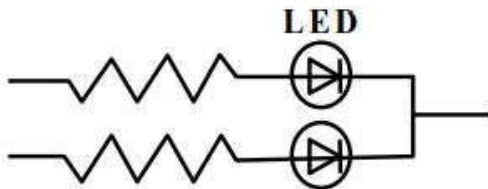

Circuit model B

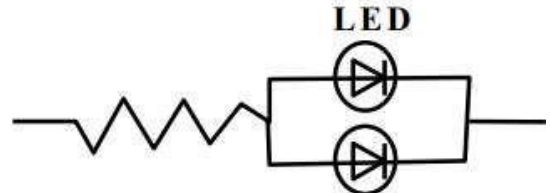

Recommended circuit

The brightness of each LED might appear different due to the differences in the I-V characteristics of those LEDs.

Repairing

Repair should not be done after the LEDs have been soldered. When repairing is unavoidable, a double-head soldering iron should be used. It should be confirmed beforehand whether the characteristics of the LEDs will or will not be damaged by repairing.

ESD (Electrostatic Discharge)

Static Electricity or power surge will damage the LED. Suggestions to prevent ESD damage:

Use a conductive wrist band or anti- electrostatic glove when handling these LEDs.

All devices, equipment, and machinery must be properly grounded.

Work tables, storage racks, etc. should be properly grounded.

Use ion blower to neutralize the static charge which might have built up on surface of the LEDs plastic lens as a result of friction between LEDs during storage and handing.

Others

The information included in this document reflects representative usage scenarios and is intended for technical reference only.

The part number, type, and specifications mentioned in this document are subject to future change and improvement without notice. Before production usage customer should refer to the latest datasheet for the updated specifications.

When using the products referenced in this document, please make sure the product is being operated within the environmental and electrical limits specified in the datasheet. If customer usage exceeds the specified limits, Queendom will not be responsible for any subsequent issues.

The LEDs described here are intended to be used for ordinary electronic equipment (such as office equipment, communication equipment and household applications). Consult Queendom's Sales in advance for information on applications in which exceptional reliability is required, particularly when the failure or malfunction of the LEDs may directly jeopardize life or health, such as in aviation, transportation, traffic control equipment, medical and life support systems and safety devices.



Copyright Statement

1. The copyright of this content (including design drafts, images, text, etc.) belongs to [QUEENDOM].
2. Any unauthorized reproduction, modification, or dissemination by any entity or individual is prohibited.
3. Infringers will be held accountable according to law.